

Series 4, washing machine, front loader, 10 kg, , Silver inox WGA2540XGC



WMZ2200 Floor securing component
 WMZ2381 Extension for cold water inlet /Aquastop

Stain expert washing machine with innovative Presoaking and AntiStain system: Automatic removal of stubborn stains even for delicate textiles with an extended capacity of 10 kg.

- Reduces wrinkles by up to 50%
- AutoStain: removes the four most common stains.
- EcoSilence Drive™: extremely energy-efficient and quiet in operation with a 10-year warranty.
- AllergyPlus: specially developed for the needs of allergy sufferers and sensitive skin.
- SpeedPerfect: perfectly clean in up to 65% less time.

Built-in / Free-standing: Free-standing
 Door hinge: Left
 Color / Material body: Silver inox
 Length electrical supply cord: 160.0 cm
 Height of the appliance: 845 mm
 Dimensions of the product: 845 x 598 x 588 mm
 Wheels: No
 Net weight: 71.8 kg
 Drum volume: 70 l
 Door Frame: Silver-inox, black-grey
 Noise level washing: 54 dB(A) re 1 pW
 Connection rating: 2300 W
 Fuse protection: 10 A
 Voltage: 220-240 V
 Frequency: 50-60 Hz
 Energy Star Qualified: Yes
 Cord Included: No
 Plug type: GB plug
 Length of supply hose (in): 59.05 "
 Dimensions of the packed product: 34.64 x 25.19 x 26.77
 Net weight: 158.000 lbs
 Gross weight: 160.000 lbs
 Length of drain hose: 150.00 cm
 Length of supply hose: 150.00 cm
 Dimensions of the packed product (HxWxD): 880 x 680 x 640 mm
 Gross weight: 72.8 kg
 Connection rating: 2300 W
 Fuse protection: 10 A
 Voltage: 220-240 V
 Frequency: 50-60 Hz
 Water protection system: Multiple water protection
 Maximum spin speed: 1400 rpm
 Spin speed options: Variable
 Digital countdown indicator: Yes
 Drying progress indicator: LED-display, LED
 Maximum capacity in kg (EU 2017/1369): 10.0 kg



Series 4, washing machine, front loader, 10 kg, , Silver inox WGA2540XGC

Stain expert washing machine with innovative PreSoaking and AntiStain system: Automatic removal of stubborn stains even for delicate textiles with an extended capacity of 10 kg.

- Ferrite-BLDC
- EcoSilence drive with 10 year warranty

Main features

- Capacity: 10 kg
- Energy Efficiency Class: 5 Energy Stars
- Energy consumption 191 kWh per year, based on 220 standard washing cycles for cotton programmes at 60°C and 40°C at full and partial load, and the consumption of the low power modes. Actual energy consumption will depend on how the appliance is used.
- energy consumption of the standard 60 °C cotton programme 1.2 kWh at full load and 0.6 kWh at partial load and of the standard 40 °C cotton programme 0.6 kWh at partial load
- weighted power consumption off-mode / left-on mode: 0.1 W / 0.5 W
- Water consumption 12100 litres per year, based on 220 standard washing cycles for cotton programmes at 60°C and 40°C at full and partial load. Actual water consumption will depend on how the appliance is used.
- spin-drying efficiency class: B
- Max. spin speed: 1400 rpm
- Cottons 60 Eco and Cottons 40 Eco are the standard washing programmes to which the information in the label relates. These programmes are suitable to clean normally soiled cotton laundry and are the most efficient programmes in terms of combined energy and water consumption.
- Programme time: 60 °C cotton programme 305 min at full load 290 min at partial load and 40 °C cotton programme 290 min partial load
- Noise level washing dB (A) re 1 pW: 54
- Noise level spinning dB (A) re 1 pW: 75
- 5 Energy Stars according to the UAE energy efficiency label with energy consumption of 173 kWh per year and water consumption of 12610 l per year

Programmes

Options

- PreSoaking: Works against stubborn stains.
- AntiStain: Automatic removal of the most common stains.
- varioPerfect: time or energy optimized programs with perfect wash performance
- Touch control buttons: Start / Reload / Pause, Reduced Ironing, SpeedPerfect, Spin speed reduction/Yes

Convenience and Safety

- Reload function: Be flexible in adding laundry items even after start of the wash cycle.
- WaveDrum
- Multiple water protection

- Large display for programme progress indication, temperature, spin speed, remaining time, 24 h end time delay and load recommendation
- Large display for temperature, spin speed, remaining time, 24 h end time delay and load recommendation
- Fully electronic control dial for all wash- and special programs
- AntiVibration Design: more stability and quietness
- 3D AquaSpa wash system with cascade for faster water penetration
- infinitely variable
- loading introduction
- Foam detection system
- Unbalanced load detection
- Self cleaning detergent drawer
- AquaSensor for optimum rinse results: Yes
- Childproof door lock
- Buzzer
- Metal door closing hook
- Magnet Lock

Technical information

- Dimensions (H x W x D): 84.5 x 59.8 x 58.8 cm
- Can be built-under

**Series 4, washing machine, front loader, 10 kg, , Silver inox
WGA2540XGC**

Measurements in mm

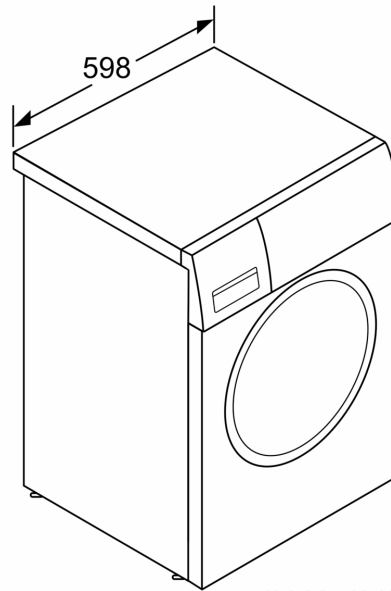
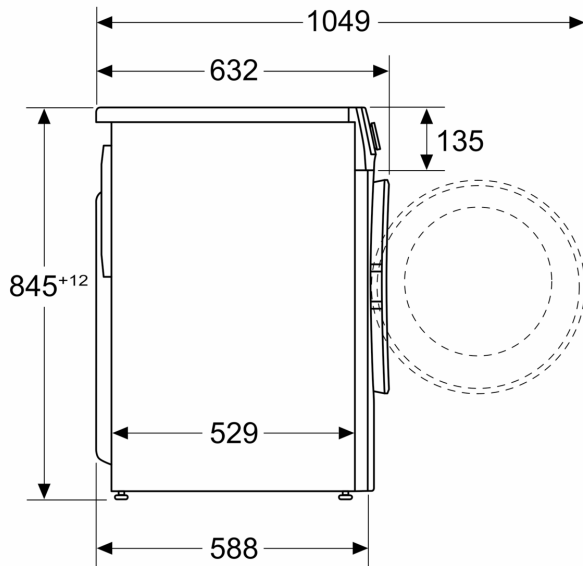

measurements in mm