

**Series 4, washing machine, front loader, 9 kg, 1400 rpm  
WGA14400GC**



**Stain expert washing machine with innovative Presoaking and AntiStain system: Automatic removal of stubborn stains even for delicate textiles.**

- Reduces wrinkles by up to 50%
- AntiStain: detects and removes the 4 most common stains.
- EcoSilence Drive™: extremely energy-efficient and quiet in operation with a 10-year warranty.
- AllergyPlus: specially developed for the needs of allergy sufferers and sensitive skin.
- SpeedPerfect: perfectly clean in up to 65% less time.

- WMZ2200 Floor securing component  
 WMZ2381 Extension for cold water inlet /Aquastop  
 WMZPW20W Platform with pull-out, washer, cubic

Built-in / Free-standing: .....	Free-standing
Door hinge: .....	Left
Color / Material body: .....	White
Length electrical supply cord: .....	160.0 cm
Height of the appliance: .....	845 mm
Dimensions of the product: .....	845 x 597 x 588 mm
Wheels: .....	No
Net weight: .....	70.3 kg
Drum volume: .....	65 l
Door Frame: .....	Silver-inox, black-grey
Noise level washing: .....	55 dB(A) re 1 pW
Connection rating: .....	2300 W
Fuse protection: .....	10 A
Voltage: .....	220-240 V
Frequency: .....	50 Hz
Energy Star Qualified: .....	Yes
Cord Included: .....	No
Plug type: .....	GB plug
Length of supply hose (in): .....	59.05 "
Dimensions of the packed product: .....	34.44 x 25.19 x 27.36
Net weight: .....	155.000 lbs
Gross weight: .....	157.000 lbs
Length of drain hose: .....	150.00 cm
Length of supply hose: .....	150.00 cm
Dimensions of the packed product (HxWxD): .....	875 x 695 x 640 mm
Gross weight: .....	71.3 kg
Connection rating: .....	2300 W
Fuse protection: .....	10 A
Voltage: .....	220-240 V
Frequency: .....	50 Hz
Energy consumption: .....	0.62 kWh
Water consumption: .....	44.0 l
Water protection system: .....	Multiple water protection
Maximum spin speed: .....	1400 rpm
Spin speed options: .....	Variable
Digital countdown indicator: .....	Yes
Drying progress indicator: .....	LED-display, LED
Maximum capacity in kg (EU 2017/1369): .....	9.0 kg



## Series 4, washing machine, front loader, 9 kg, 1400 rpm WGA14400GC

### Stain expert washing machine with innovative PreSoaking and AntiStain system: Automatic removal of stubborn stains even for delicate textiles.

- Metal door closing hook
- Magnet Lock

#### Technical information

- Dimensions (H x W x D): 84.5 x 59.7 x 58.8 cm
- Can be built-under
- Appliance depth incl. door: 63.2 cm
- Appliance depth with open door: 104.9 cm
- Appliance depth: 58.8 cm

- 
- Ferrite-BLDC
  - EcoSilence drive with 10 year warranty

#### Main features

- Capacity: 9 kg
- Energy Efficiency Class: 5 Energy Stars
- spin-drying efficiency class: B
- Max. spin speed: 1400 rpm
- Cottons 60 Eco and Cottons 40 Eco are the standard washing programmes to which the information in the label relates. These programmes are suitable to clean normally soiled cotton laundry and are the most efficient programmes in terms of combined energy and water consumption.
- Noise level washing dB (A) re 1 pW: 55
- Noise level spinning dB (A) re 1 pW: 73
- 5 Energy Stars according to the UAE energy efficiency label with energy consumption of 151 kWh per year and water consumption of 10920 l per year

#### Programmes

##### Options

- PreSoaking: Works against stubborn stains.
- AntiStain: Automatic removal of the most common stains.
- varioPerfect: time or energy optimized programs with perfect wash performance
- Touch control buttons: Start / Reload / Pause, Reduced Ironing, SpeedPerfect, Spin speed reduction/Yes

##### Convenience and Safety

- Reload function: Be flexible in adding laundry items even after start of the wash cycle.
- WaveDrum
- Multiple water protection
- Large display for programme progress indication, temperature, spin speed, remaining time, 24 h end time delay and load recommendation
- Large display for temperature, spin speed, remaining time, 24 h end time delay and load recommendation
- Fully electronic control dial for all wash- and special programs
- AntiVibration Design: more stability and quietness
- 3D AquaSpa wash system with cascade for faster water penetration
- infinitely variable
- loading introduction
- Foam detection system
- Unbalanced load detection
- Self cleaning detergent drawer
- AquaSensor for optimum rinse results: Yes
- Childproof door lock
- Buzzer

**Series 4, washing machine, front  
loader, 9 kg, 1400 rpm  
WGA14400GC**

Measurements in mm

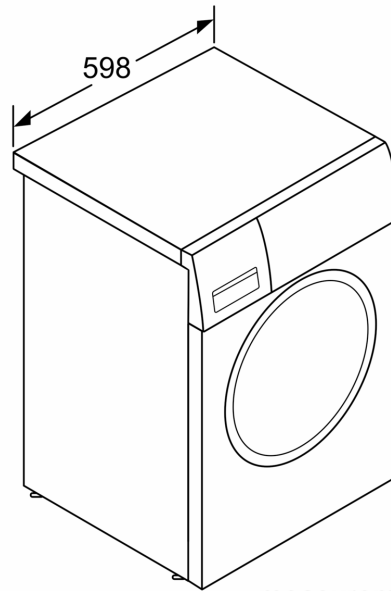

measurements in mm