

Serie | 6, Built-In Microwave, Width 60 cm
BFL524MS0M



Included accessories
 1 x Turntable

The built-in microwave for the 38 cm niche: use it for thawing, heating and perfect preparation of foods.

- **AutoPilot 7:** every dish is a perfect success thanks to 7 pre-set automatic programmes.
- **Pop-out controls:** for an easy to clean front.
- Triple Distribution Turntable Disk - provides improved distribution of microwave energy for more even cooking.
- SpeedChef™ Cooking Cycles Offer Faster Cooking Times for Your Convenience
- A Large Cooking Interior Gives You Flexibility to Cook Various Dishes

Technical Data

Type of micro-wave oven :	MW only
Type of control :	Electronic
Color / Material Front :	Stainless steel
Dimensions :	382 x 594 x 317
Cavity dimensions (mm) :	201.0 x 308.0 x 282.0
Length electrical supply cord (cm) :	130
Net weight (kg) :	16.208
Gross weight (kg) :	18.2
Maximum micro-wave power (W) :	800
Number of Power Levels :	5
Turntable :	Yes
Cavity material :	Stainless steel
Door opening :	Button
Clock :	Yes
Included accessories :	1 x Turntable
Main colour of product :	Stainless steel
Height of the product (mm) :	382
Width of the appliance :	594
Depth of the product :	317
Maximum micro-wave power (W) :	800
Connection Rating (W) :	1270
Current (A) :	10
Voltage (V) :	230-240
Frequency (Hz) :	50
Plug type :	GB plug
Color / Material Front :	Stainless steel
Approval certificates :	CE, G-Mark
Appliance Dimensions (h x w x d) (in) :	x x
Dimensions of the packed product (in) :	16.92 x 15.15 x 25.19
Net weight (lbs) :	36.000
Gross weight (lbs) :	40.000



4 242005 038756

Serie | 6, Built-In Microwave, Width 60 cm BFL524MS0M

**The built-in microwave for the 38 cm niche:
use it for thawing, heating and perfect
preparation of foods.**

Microwave and Heating System

- Cavity volume: 20 l

Design:

- Stainless steel cavity

Comfort:

- LED
- electronic clock
- User-friendly electronics: extremely easy and comfortable operation
- automatic programming, 7
- 4 defrost and 3 cooking programmes in microwave function
- memory function (1 setting)
- LED light
- Turn table 25.5 cm Glass
- side opening door, hinge left

Accessory:

- 1 x Turntable

Environment and Safety:

- Safety switch door contact switch
- Integral cooling fan

Technical Info:

- Length of mains cable: 130 cm
- Total connected load electric: 1.27 KW
- Nominal voltage: 230 - 240 V
- Can be built in a 60 cm wall cupboard (at least 30cm deep)

Dimensions:

- Appliance dimension (hxwx): 382 mm x 594 mm x 317 mm
- Niche dimension (hxwx): 560 mm - 568 mm x 362 mm - 365 mm x 300 mm
- "Please reference the built-in dimensions provided in the installation drawing"
- Max. Power: 800 W; 5 Microwave power settings: 90 W, 180 W, 360 W, 600 W, 800 W
- Rotary Control, Pop-out controls, Touch control
- Open Button, electric
- Touch key operation

Serie | 6, Built-In Microwave, Width 60 cm BFL524MS0M

Microwave,
corner installation

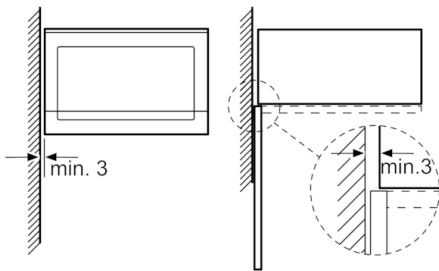

Measurements in mm

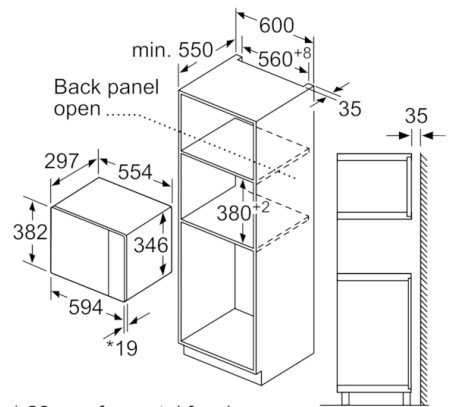

measurements in mm

measurements in mm

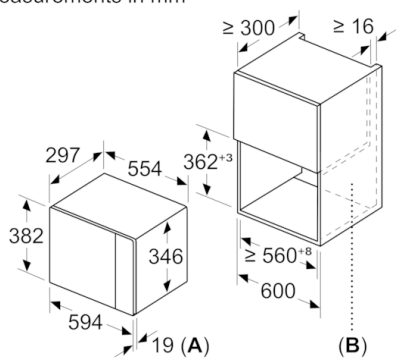

A: 20 mm for metal fascia
B: Back panel open