

**Serie | 2, built-in fridge-freezer with freezer at bottom, 177.2 x 54.1 cm, sliding hinge  
KIV38X22GB**



**Included accessories**  
1 x butter dish



**The bottom freezer with MultiBox: lots of space for your fruits and vegetables.**

- **Multi Box XXL:** extra-large drawer for your fruit and vegetables.

**Technical Data**

Energy Efficiency Class: G  
 Average annual energy consumption in kilowatt hour per year (kWh/a): 341 kWh/annum  
 Sum of volume of frozen compartments: 64 l  
 Sum of volume of chill compartments: 217 l  
 Airborne acoustical noise emissions : 40 dB(A) re 1 pW  
 Airborne acoustical noise emission class: C  
 Built-in / Free-standing: Built-in  
 Number of compressors: 1  
 Number of independent cooling systems: 1  
 Width of the appliance: 541 mm  
 Depth of the product: 545 mm  
 Net weight: 56.9 kg  
 Required niche size for installation (HxWxD): 1775.0 x 562.0 x 550 mm  
 Door panel options: Not possible  
 Door hinge: Right reversible  
 Number of Adjustable Shelves in fridge compartment: 4  
 Shelves for Bottles: No  
 Frost free system: No  
 Interior ventilator: No  
 Reversible Door Hinge: Yes  
 Length electrical supply cord: 230 cm  
 Noise level: 40 dB(A) re 1 pW  
 Multi-Flow Air Tower: No  
 Fast cooling switch: No  
 Fast freezing switch: Yes  
 Temperature Controlled Drawer: No  
 Humidity Control Drawer: No  
 Number of Door Bins - Refrigerator: 5  
 Door bin adjustability - Refrigerator: No  
 Tilt-out door bins in fridge: Yes  
 Gallon wide door bins: Yes  
 Number of Gallon storage: 5  
 Motorized Shelf: No  
 Material of the shelves: Safety glass  
 Door opened indicator freezer: No  
 Automatic motor-driven ice-maker: No  
 Connection Rating: 90 W  
 Fuse protection: 13 A  
 Voltage: 220-240 V  
 Frequency: 50 Hz  
 Storage Period in Event of Power Failure (h): 7 h  
 Approval certificates: VDE  
 Main colour of product: N/A  
 Door panel options: Not possible  
 Noise level: 40 dB(A) re 1 pW  
 Energy Star Qualified: No  
 Approval certificates: VDE  
 Plug type: GB plug  
 Required cutout/niche size for installation (in): x x  
 Dimensions of the packed product: 73.22 x 24.40 x 25.19  
 Net weight: 125.000 lbs  
 Gross weight: 136.000 lbs



4 242002 763200

## Serie | 2, built-in fridge-freezer with freezer at bottom, 177.2 x 54.1 cm, sliding hinge KIV38X22GB

**The bottom freezer with MultiBox: lots of space for your fruits and vegetables.**

### General Information

- EU19\_EEK\_D: G
- Total Volume : 281 l
- Net Fridge Volume : 217 l
- Net Freezer Volume : 64 l
- Annual Energy Consumption: 341 kWh/a
- Climate Class: SN-ST
- Fast Freeze Facility
- Noise Level : 40 dB , EU19\_Noise emission class\_D: C
- Temperature rise time : 7 H

### Performance and consumption

#### Design and Styling

- Easy clean interior

#### Convenience & Safety

- LED electronic control
- Automatic defrost in fridge section

#### Fridge Compartment

- 5 safety glass shelves, of which 4 are height adjustable
- 5 door trays high

#### Freshness System

- 1 MultiBox - Transparent drawer with a corrugated bottom, ideal for storing fruits and vegetables.

#### Freezer Section

- 3 transparent freezer drawers

#### Dimensions

- Appliance Dimensions ( H x W x D): 177.2 cm x 54.1 cm x 54.5 cm
- Niche Dimension (H x W x D): 177.5 cm x 56.2 cm x 55.0 cm

#### Technical Information

- Door right hinged, reversible
- Connected load: 90 W
- Nominal voltage: 220 - 240 V

#### Accessories

- butter dish

#### Country Specific Options

- Based on the results of the standard 24-hour test. Actual consumption depends on usage/position of the appliance.

#### Environment and Safety

#### Installation

**Serie | 2, built-in fridge-freezer with freezer at bottom, 177.2 x 54.1 cm, sliding hinge KIV38X22GB**

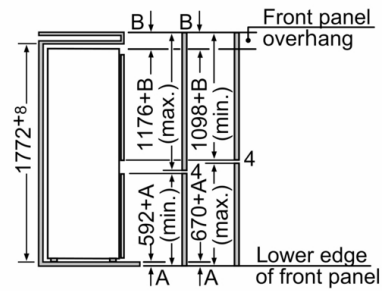
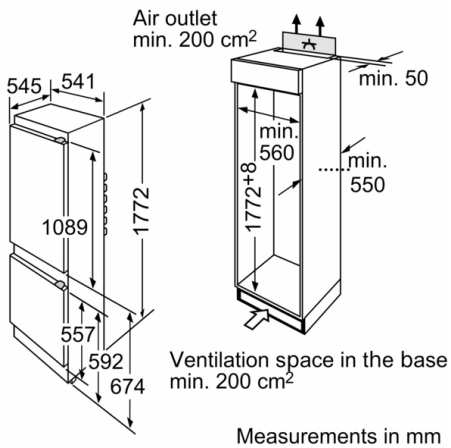

The specified unit door dimensions are valid for a door gap of 4 mm. If a different gap width is used (max. 14 mm), the dimensions must be adjusted.

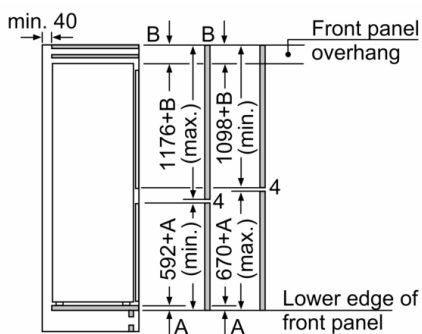
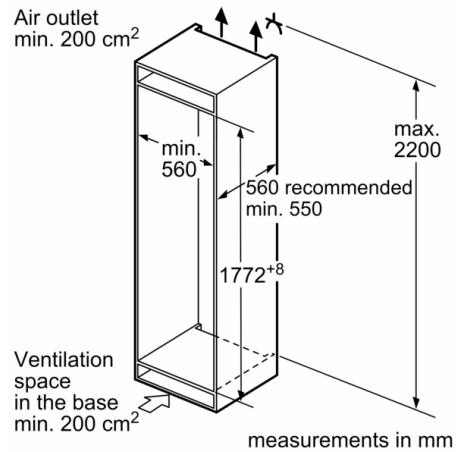
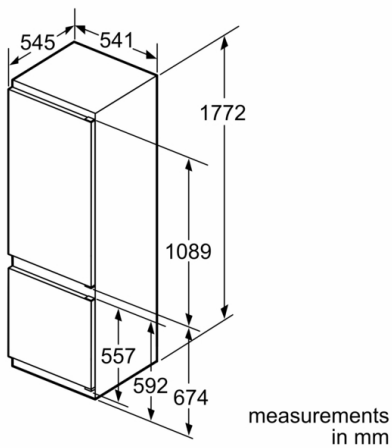

The specified unit door dimensions are valid for a door gap of 4 mm.

measurements in mm